

**INVITATION TO BID**  
**DEVIL’S HOLE BOARDWALK REPLACEMENT**  
**NORTHWEST FLORIDA WATER MANAGEMENT DISTRICT**  
**(BID NUMBER 25B-002)**

The Northwest Florida Water Management District (District), 81 Water Management Drive, Havana, Florida 32333-4712, is soliciting bids for the Devil’s Hole Boardwalk Replacement project for the removal and disposal of existing damaged boardwalk and stair segments and the reconstruction of these segments (the “Work”) according to the specifications of the attached construction plans and Attachment A - Scope of Work. The Contractor shall furnish all materials, labor and equipment, tools, incidentals, transportation, and all services necessary for the completion of this Work.

The deadline for submission of bids and the opening of the sealed bids is 2:00 P.M. Eastern Time (ET) October 16, 2024. The bid opening is open to the public. Provisions will be made to accommodate those with a disability provided the District is given at least 72 hours advance notice. All bids must conform to the instructions in the Invitation to Bid (ITB) and comply with applicable Florida Statutes. The respondent must submit its Bid through DemandStar (see Section 1.13 for more information). Interested parties may obtain a copy of the complete ITB package from the District’s website (<http://www.nwfwater.com>) or a copy of the complete ITB package may be obtained from the State of Florida’s Vendor Information Portal website at: [MyFloridaMarketPlace Vendor Information Portal](#). A copy of the complete ITB package can also be obtained at the above address or by calling (850) 539-5999.

# Table of Contents

**PAGE**

---

<b>PART 1</b>	<b>GENERAL INFORMATION</b>	
1.1	Definitions.....	4
1.2	Purpose.....	4
1.3	Issuing Office, Date and ITB Opening .....	4
1.4	Invitation to Bid .....	4
1.5	Awarding of Bid .....	4
1.6	Development Costs .....	5
1.7	Conflict of Interest .....	5
1.8	District Forms and Rules .....	5
1.9	Mandatory Pre-Bid Conference and/or Oral Presentations .....	5
1.10	Inquiries and Addenda .....	5
1.11	Timetable .....	6
1.12	Delays .....	6
1.13	Submission and Withdrawal .....	6
1.14	Equal Opportunity.....	7
1.15	Americans with Disabilities Act .....	7
1.16	Social, Political and Ideological Interests.....	7
1.17	Public Crimes/Discriminatory/Antitrust Violator Vendors .....	8
1.18	Scrutinized Companies, Boycotting.....	8
1.19	Inspector General Cooperation .....	8
1.20	Compliance with Health and Safety Regulations .....	8
1.21	Insurance .....	9
1.22	Prohibited Contact .....	9
1.23	Specification and Award Protest.....	9
1.24	Publicity .....	9
1.25	Waiver of Minor Irregularities.....	9
1.26	Performance Bond .....	10
<b>PART 2</b>	<b>SCOPE OF SERVICES.....</b>	<b>11</b>
<b>PART 3</b>	<b>BID REQUIREMENTS.....</b>	<b>12</b>
3.1	Rules for the Bids.....	12
3.2	Contractor Qualifications.....	12
3.3	Bid Bond .....	13

3.4	Vendor Registration and W-9 Forms.....	13
3.5	Vendor Checklist .....	13
<b>PART 4</b>	<b>EVALUATION OF BIDS .....</b>	<b>14</b>
4.1	Evaluation Method and Criteria.....	14
<b>PART 5</b>	<b>BID SHEETS AND BIDDER ACKNOWLEDGMENT .....</b>	<b>15</b>
5.1	Bid Sheets .....	15
5.2	Bidder Information Form.....	17
<b>PART 6</b>	<b>DRAFT AGREEMENT.....</b>	<b>18</b>
<b>ATTACHMENTS (INCLUDED IN DRAFT AGREEMENT)</b>		
<b>ATTACHMENT A - SCOPE OF WORK</b>		
<b>EXHIBIT 1 - CONTRACTORS BID SUBMITTAL</b>		
<b>EXHIBIT 2 - DEVIL’S HOLE CONSTRUCTION PLANS</b>		

## **PART 1. GENERAL INFORMATION**

### **1.1 DEFINITIONS**

For the purpose of this bid, “respondent” or “bidder” means contractor, vendors, consultants, organizations, firms, or other persons submitting a response to this Invitation to Bid.

### **1.2 PURPOSE**

The Northwest Florida Water Management District, 81 Water Management Drive, Havana, Florida 32333, (hereinafter referred to as the “District”) is issuing this Invitation to Bid (ITB) for the project titled **“Devil’s Hole Boardwalk Replacement.”**

### **1.3 ISSUING OFFICE, DATE AND LOCATION OF OPENING**

Northwest Florida Water Management District (Headquarters)  
Attn: Agency Clerk  
81 Water Management Drive  
Havana, Florida 32333-4712

**THE DISTRICT MUST RECEIVE ALL BIDS BY 2:00 P.M. EASTERN TIME (ET), OCTOBER 16, 2024, THE DAY OF THE PUBLIC OPENING.**

### **1.4 INVITATION TO BID**

The District solicits offers for the services of responsible bidders to perform “Devil’s Hole Boardwalk Replacement” for the removal and disposal of existing damaged boardwalk segments and the reconstruction of these segments according to the specifications of the attached construction plans and Attachment A - Scope of Work.

### **1.5 AWARDING OF BID**

The District anticipates entering into a contract with the bidder who submits a qualified responsive bid judged by the District to be the lowest total lump sum cost for the specified services. The District reserves the right to award the bid to the next lowest responsive bidder in the event the successful bidder fails to enter into the Agreement, or the Agreement with said bidder is terminated within 90 days of the effective date.

**The respondent understands this bid does not constitute an agreement or a contract with the District. An official contract or agreement is not binding until the bids are reviewed and accepted by appointed staff, approved by the appropriate level of authority within the District, and the contract or agreement is executed by both parties.**

The District reserves the right to reject any and all bids, to negotiate with the qualified respondent submitting the lowest bid, to waive any irregularities of a minor nature, and to solicit and re-advertise for other bids. Mistakes clearly evident on the face of the bid documents, such as computation errors, may be corrected by the District. Per s. 255.0991, F.S., the District has no regulation that provides contractor preference as described in that statute.

All bids may be subject to the approval of the Northwest Florida Water Management District Governing Board at a duly noticed Board meeting.

Notice of a bid award shall be posted to the District's website and the State of Florida's Vendor Information Portal website.

## **1.6 DEVELOPMENT COSTS**

The District shall not be responsible or liable for any expenses incurred in connection with the preparation of a response to this bid. Respondents should prepare the bid simply and economically, to provide a straightforward and concise description of the respondent's ability to meet the requirements of the bid.

## **1.7 CONFLICT OF INTEREST**

The award hereunder is subject to Ch. 112, F.S. All bidders shall disclose with their bids the name of any officer, director, board member or agent who is also an employee of the State of Florida, or any of its agencies. Further, all bidders shall disclose the name of any state employee or any board member or employee of the District who owns directly or indirectly an interest of five percent (5%) or more in the bidder's firm, subsidiaries, or branches. If none, state none.

## **1.8 DISTRICT FORMS AND RULES**

When included, all forms supplied by the Northwest Florida Water Management District shall be submitted with the bids. All bids must comply with applicable Florida Statutes, laws, and rules.

## **1.9 MANDATORY PRE-BID CONFERENCE AND/OR ORAL PRESENTATIONS**

There will not be a mandatory pre-bid conference.

There will not be oral presentations for this solicitation.

## **1.10 INQUIRIES AND ADDENDA**

All questions regarding this ITB shall be provided in writing and emailed to the Procurement Officer, Lyn Shiver at [Lyn.Shiver@nwfwater.com](mailto:Lyn.Shiver@nwfwater.com), no later than 12:00 P.M. (Noon) Eastern Time (ET) on October 1, 2024. Inquiries shall reference the date of the ITB opening and ITB title and number.

If addenda become necessary, the District will provide written addenda and post addenda on the District's website and on the State of Florida's Vendor Information Portal website at least ten (10) calendar days before the bid opening date. Prospective bidders are responsible for determining whether addenda have been issued and are advised to check the websites or with the District's Procurement Officer prior to submitting their bid.

Submission of a bid constitutes acknowledgment of receipt of all addenda. Bids will be construed as though all addenda have been received. Failure of the respondent to obtain any addenda does not relieve respondent from any and all obligations under the bid, as submitted. All addenda become part of the Contract Documents.

## 1.11 TIMETABLE

The District and respondents shall adhere to the following schedule in all actions concerning this bid.

- On September 19, 2024, the District issues the Invitation to Bid.
- From the time of issuance on September 19, 2024 until 12:00 P.M. (Noon) Eastern Time (ET) on October 1, 2024, the District will receive written inquiries by email on the ITB.
- If substantive written inquiries are received, District will issue an Addendum to respond to such inquiries at least ten (10) calendar days prior to bid opening.
- Bid Opening Deadline: The sealed bids will be opened at 2:00 P.M. Eastern Time (ET), October 16, 2024\*. Bids received after the bid opening deadline will not be considered.
- From opening time, the District will review and evaluate the bids on a timely basis.
- The District may enter into a contract with the qualified Contractor submitting the lowest responsive bid after conducting negotiations and obtaining appropriate approvals.

\*Denotes a public meeting.

## 1.12 DELAYS

The District may delay scheduled due dates if it is to the advantage of the District to do so. The District will notify respondents of all changes in scheduled due dates by posting the information to the District's website and State of Florida's Vendor Information Portal website.

## 1.13 SUBMISSION AND WITHDRAWAL

Respondents must submit electronically through DemandStar. **All bid submissions will be accepted through DemandStar only.**

- 1) Submittals are accepted through the District's online bid system, DemandStar. Respondents must be registered with DemandStar in order to submit their responses on the DemandStar website. To register, please visit the DemandStar website at: [www.demandstar.com/app/registration](http://www.demandstar.com/app/registration).
- 2) For instructions on how to complete a free registration with DemandStar, please consult the [District's DemandStar overview](#).
- 3) Instructions for submitting an online bid are available on the District's website at: <https://nwfwater.com/business-finance/district-procurement/>.

Bids not submitted through DemandStar do not constitute "delivery" and are not considered "received by" the District as required by this ITB. Submittal of bids other than through DemandStar shall not be accepted.

It is the respondent's responsibility to ensure his/her bid submission is delivered at the proper time. **Bids that are, for any reason, received after the established deadline will not be considered.**

A respondent may withdraw a bid by notifying the District electronically at any time prior to the opening. Bids, once opened, become the property of the District and will not be returned to the respondents.

All bids must be made on the required **Forms** (see Part 5). All blank spaces for bid prices must be filled in, in ink or typewritten, and the form must be fully completed and executed when submitted.

Respondents must satisfy themselves of the accuracy of their responses on the **Forms** by examination of the criteria and specifications including addenda. After bids have been submitted, respondents shall not assert that there was a misunderstanding concerning the number or type of parameters nor the accuracy required of each parameter.

Bids received by the District in response to this ITB will become a public record (unless an exemption to Florida's Public Records Law applies) when the District provides notice of its intended decision or 30 days after opening the bids, whichever is earlier. If the District rejects all bids and concurrently provides notice of its intent to reissue the ITB, the rejected bids remain exempt from Florida's Public Records Law until such time as the District provides notice of an intended decision concerning the reissued ITB or until it withdraws the reissued ITB. A bid is not exempt for longer than 12 months after the initial notice rejecting all bids.

Bids will be made available for inspection at the time the District posts notice of its decision or intended decision concerning contract awards or 30 days after the bid opening, whichever is earlier.

#### **1.14 EQUAL OPPORTUNITY**

The District recognizes fair and open competition as a basic tenet of public procurement. Respondents doing business with the District are prohibited from discriminating on the basis of race, color, creed, national origin, handicap, age, sex, or disability. It is the policy of the District to ensure that qualified respondents wishing to participate in the procurement process have the maximum opportunity to compete and perform on District contracts and purchases.

The District encourages participation by minority-, veteran-, and women-owned Certified Business Enterprises and requests that respondents submit evidence of such designation with their bids. For further information on designation as a certified business enterprise, visit:

[www.dms.myflorida.com/agency\\_administration/office\\_of\\_supplier\\_diversity\\_osd/get\\_certified](http://www.dms.myflorida.com/agency_administration/office_of_supplier_diversity_osd/get_certified).

#### **1.15 AMERICANS WITH DISABILITIES ACT**

The District does not discriminate upon the basis of any individual's disability status. This nondiscrimination policy involves every aspect of the District's functions including one's access to, participation, employment, or treatment in its programs or activities. Anyone requiring reasonable accommodation as provided for in the Americans with Disabilities Act should contact Jack Furney, Division of Administrative Services, at (850) 539-5999.

#### **1.16 SOCIAL, POLITICAL AND IDEOLOGICAL INTERESTS**

In accordance with s. 287.05701, F.S., the District shall not request documentation of or consider a respondent's social, political, or ideological interests in determining if the respondent is a responsible vendor. The District shall not give preference to a respondent based on the respondent's social, political, or ideological interests.

## **1.17 PUBLIC CRIMES/DISCRIMINATORY/ANTITRUST VIOLATOR VENDORS**

In accordance with sections 287.133, 287.134, and 287.137, F.S., a person or affiliate who has been placed on the convicted, discriminatory, or antitrust violator vendor lists may not submit a bid, proposal, or reply on a contract to provide any goods or services to a public entity; may not submit a bid, proposal, or reply on a contract with a public entity for the construction or repair of a public building or public work; may not submit bids, proposals, or replies on leases of real property to a public entity; may not be awarded or perform work as a contractor, supplier, subcontractor, or consultant under a contract with any public entity; and may not transact business with any public entity in excess of the threshold amount provided in s. 287.017, F.S., for CATEGORY TWO (\$35,000), unless specified otherwise in these statutes. Questions regarding the lists may be directed to the Florida Department of Management Services, State Purchasing Division, at (850) 488-8440 or send email to [purchasingcustomerservice@dms.fl.gov](mailto:purchasingcustomerservice@dms.fl.gov).

## **1.18 SCRUTINIZED COMPANIES, BOYCOTTING**

Pursuant to s. 287.135, F.S., a company is ineligible to, and may not, bid on, submit a proposal for, or enter into or renew a contract with the District for goods or services of:

1. Any amount if, at the time of bidding on, submitting a proposal for, or entering into or renewing such contract, the company is on the Scrutinized Companies that Boycott Israel List, created pursuant to s. 215.4725, F.S., or is engaged in a boycott of Israel; or
2. One million dollars or more if, at the time of bidding on, submitting a proposal for, or entering into or renewing such contract, the company:
  - a. Is on the Scrutinized Companies with Activities in Sudan List or the Scrutinized Companies with Activities in the Iran Petroleum Energy Sector List, created pursuant to s. 215.473, F.S.; or
  - b. Is engaged in business operations in Cuba or Syria.

By submitting a response, the respondent certifies that it is not currently on the aforementioned lists or engaged in such business operations and agrees to notify the District if placement on one of these lists occurs or the respondent engages in such business operations. If the respondent submits a false certification, the District may terminate the Agreement and bring a civil action against the respondent, as provided for in s. 287.135, F.S.

## **1.19 INSPECTOR GENERAL COOPERATION**

Respondent understands and shall comply with s. 20.055(5), F.S., which states: "It is the duty of every state officer, employee, agency, special district, board, commission, contractor, and subcontractor to cooperate with the inspector general in any investigation, audit, inspection, review, or hearing pursuant to this section."

## **1.20 COMPLIANCE WITH HEALTH AND SAFETY REGULATIONS**

Respondent shall comply with all applicable federal, state, and local rules and regulations in providing services to the District. This requirement includes compliance with all applicable federal, state, and local health and safety rules and regulations.



## 1.21 INSURANCE

The respondent, if awarded a contract, shall maintain insurance coverage. In the event a contract is awarded to a governmental entity or a self-insured organization, different insurance requirements may apply. Misrepresentation of any material fact, whether intentional or not, regarding the bidder's insurance coverage, policies, or capabilities may be grounds for rejection of the bid and rescission of any ensuing contract. The respondent shall obtain all coverage as required by Florida law, including Workers Compensation and applicable professional liability insurance. Additionally, the respondent shall be insured as follows: General Liability, with limits not less than \$1,000,000 per occurrence; \$1,000,000 per occurrence for personal injury; and \$1,000,000 for property damage; Automobile Liability, with combined single limit of not less than \$1,000,000; Workers Compensation and Employers Liability, with limits not less than: Bodily Injury by Accident \$1,000,000 each accident; Bodily Injury by Disease \$1,000,000 policy limit; and Bodily Injury by Disease \$1,000,000 each employee.

Evidence of all such insurance satisfactory to the District shall be furnished with the executed Agreement prior to beginning work, and all such insurance policies shall provide for a ten (10) business day notice to the District of cancellation, or any material change in the terms of the insurance policies.

## 1.22 PROHIBITED CONTACT

Respondents to this solicitation or persons acting on their behalf shall not contact, between the release of the solicitation and the end of the 72-hour period following the District posting the notice of intended award, excluding Saturdays, Sundays, and state holidays, any employee or officer of the executive or legislative branch concerning any aspect of this solicitation, except in writing to the Procurement Officer or as provided in the solicitation documents. Violation of this provision may be grounds for rejecting a response.

## 1.23 SPECIFICATION AND AWARD PROTEST

Any person who is adversely affected by the District's award shall file with the District a notice of protest in writing within 72 hours after the posting of the award. With respect to a protest of the terms, conditions, and specifications contained in this ITB, including any provisions governing the methods for ranking bids, awarding contracts, reserving rights of further negotiation, or modifying or amending any contract, the notice of protest shall be filed in writing within 72 hours after the posting of the ITB or the addenda to the ITB that contains the new term, condition or specification that is protested. The formal written protest shall be filed within 10 days after the date the notice of protest is filed with a bond pursuant to s. 287.042(2)(c), F.S. Failure to file a notice of protest or failure to file a formal written protest shall constitute a waiver of proceedings under Ch. 120, F.S. The formal written protest shall state with particularity the facts and law upon which the protest is based. Saturdays, Sundays, and state holidays shall be excluded in the computation of the 72-hour time periods. **Failure to file a protest within the time prescribed in s. 120.57(3), F.S., or failure to post the bond or other security required by law within the time allowed for filing a bond shall constitute a waiver of proceedings under Ch. 120, F.S.**

## 1.24 PUBLICITY

The respondent shall obtain prior approval of the District for all news releases or other publicity pertaining to this bid or the service or any project to which it relates.

## 1.25 WAIVER OF MINOR IRREGULARITIES

The District may waive minor irregularities in bids received where such is merely a matter of form and

not substance. Minor irregularities are defined as any deviation from a mandatory requirement of the ITB that, if waived, will not have an adverse effect on the District's interest and will not give a respondent an advantage or benefit not enjoyed by the other respondents. The District is not required to waive a minor irregularity and has the sole discretion to determine whether a minor irregularity should be waived.

## **1.26 PERFORMANCE BOND**

A performance bond in the amount of ten percent (10%) of the total contract amount (bidder's total lump sum bid), with a corporate surety approved by the District, will be required for the faithful performance of the contract. A certified Cashier's Check made payable to: "NFWWMD" may be provided to the District, in lieu of a surety performance bond.

Attorneys-in-fact who sign bid bonds and performance bonds must file with each bond a certified and effective dated copy of their power of attorney.

The successful bidder will be required to execute the contract and provide the performance bond within ten (10) calendar days once the successful bidder is notified by the District Project Manager. In case of failure of the bidder to execute the Agreement, the District may at its option consider the bidder in default, in which case the bid bond accompanying the bid proposal shall become the property of the District.

## **PART 2. SCOPE OF SERVICES**

The Work entails the removal and disposal of approximately 75 linear feet of existing damaged boardwalk and stair segments and the replacement of these segments at the Devil's Hole Recreation Area, located at 1032 Walsingham Bridge Road, Chipley, FL 32425, (Lat 30.493209, Long -85.518793), Washington County, Florida, according to the specifications of the attached Devil's Hole Swallet Construction Plans and Attachment A - Scope of Work. The respondent shall furnish all materials, labor, equipment, tools, incidentals, transportation, acquire permits as applicable, and complete all services necessary for the completion of this Work.

### **PROJECT SCHEDULE AND PHASING OF WORK**

The Work will begin upon the successful execution of an Agreement between the Northwest Florida Water Management District and the Contractor. All Work must be completed by March 31, 2025.

### **WORK SITE AND DISPOSAL OF MATERIALS**

The respondent will be required to keep the work site clean and free of construction debris and all work materials shall be secured and stored in a neat and organized manner. All construction debris shall be disposed of at an appropriate landfill. The respondent shall provide scale tickets of disposed debris upon request.

### **INVOICING**

The respondent may submit invoices for **completed Work** no more frequently than monthly. The District will not pay for stored materials and will only pay for work that has been completed according to the plans and specifications provided. If an invoice is submitted for a portion of an individual boardwalk project, the District will measure the total length of boardwalk section that has been completed and is being invoiced for and divide this by the total project distance and then multiply this by the Lump Sum Bid amount for the specific project to determine the invoice total.

## PART 3. BID REQUIREMENTS

### 3.1 RULES FOR THE BIDS

1. All bids must comply with applicable Florida Statutes, laws, and rules.
2. **One electronic bid** must be submitted through DemandStar. See Part 1, *Section 1.13 Submission and Withdrawal* for further details.
3. All bids shall be completed and submitted on the attached **Forms** (Part 5).
4. The District is not subject to Florida sales tax or to any federal excise taxes on all sales made **directly** to the District, and neither shall be included in the bid price.
5. Any transportation or other charges incurred in the delivery of products or services as specified must be included in the bid price, as noted on the bid sheet.
6. All costs, whether direct or indirect, which will be ultimately paid by the District must be included in the price on the **Bid Form** (Part 5). Any indirect, overhead, profit margin or other such costs, however named, must also be included in the bid price.
7. The award hereunder is subject to Ch. 112, F.S. All bidders shall disclose with their bids the name of any officer, director, board member, or agent who is also an employee of the State of Florida, or any of its agencies. Further, all bidders shall disclose the name of any state employee or any board member or employee of the District who owns directly or indirectly an interest of five percent (5%) or more in the bidder's firm, subsidiaries, or branches.
8. The successful bidder will be required to execute the contract and provide the performance bond within ten (10) calendar days once the successful bidder is notified by the District Project Manager. In case of failure of the successful bidder to execute the agreement within the timeline above, the District may at its option consider the bidder in default, in which case the District may award the bid to another bidder at its sole discretion.
9. The District reserves the right to reject any and all bids, to negotiate with the qualified respondent(s) submitting the lowest responsive bids, to waive any irregularities of a minor nature, and to solicit and re-advertise for other bids. Mistakes clearly evident on the face of the bid documents, such as computation errors, may be corrected by the District. Per s. 255.0991, F.S., the District has no regulation that provides contractor preference as described in the statute.

### 3.2 RESPONDENT QUALIFICATIONS

Respondents to this ITB are required to meet the following qualification and experience criteria:

1. Must hold an active Florida Contractor License.
2. Must have no less than five (5) years of experience performing similar services described in the **Scope of Work**.

3. Must have sufficient qualified personnel and equipment necessary to complete all work proposed in the Scope of Work within the established Project Schedule.
4. **Must not have** known or potential conflicts-of-interest in performing tasks as requested in the **Scope of Work**.
5. **Must not have** pertinent litigation filed against the respondent in the states of Florida, Alabama, or Georgia within the last three (3) years.
6. Any subcontractors used by the respondent to complete proposed work in this ITB must be identified and must meet the pertinent criteria listed above to perform the task for which they are hired. The successful bidder shall supply the names and addresses of major material suppliers and sub-vendors when requested to do so by the District.
7. Respondents must complete, sign, and submit with their bid the **Contractor Information Form** (see PART 5) to support and document the qualification and experience criteria listed above.

### 3.3 BID BOND

A Bid Bond will not be required for ITB 25B-002.

### 3.4 VENDOR REGISTRATION AND W-9 FORMS

The successful bidder will be required to complete a Vendor Registration Form and W-9 Form once notified of award by the District Project Manager.

### 3.5 RESPONDENT CHECKLIST

Please review the checklist for this bid (ITB No. 25B-002) to ensure that you have properly followed the instructions. Many bids and proposals are rejected because the respondent simply failed to comply with required preparation and submission requirements.

- Have you performed a final review of your bid to ensure you included all required documentation? **The omission of required items will result in rejection of the bid.**
- Have you completed, signed, and included the **Forms (pages 15 through 17)**? Have you verified all amounts to ensure that they are complete and accurate?
- If a conflict of interest exists as described in *Section 1.7 Conflict of Interest*, have you included a statement of disclosure?
- Have you verified the submittal of your complete Bid Package through DemandStar before the deadline?

## **PART 4. EVALUATION OF BIDS**

### **4.1 EVALUATION METHOD AND CRITERIA**

The District will evaluate all bids and anticipates awarding the Devil's Hole Boardwalk Replacement Project to one bidder based upon the lowest total lump sum amount bid for completing all services.

Evaluation of the Bid Package will be carried out by staff of the Northwest Florida Water Management District using the criteria listed below:

1. The successful bidder must meet the qualifications and experience criteria as described in *Section 3.2 Respondent Qualifications*.
2. The Devil's Hole Boardwalk Replacement Project will be awarded to one respondent based upon the lowest total lump sum bid amount for the completion of all Work according to Construction Plans and Scope of Work, inclusive of all materials, labor, equipment, tools, incidentals, transportation, acquiring permits as applicable, and completing all services necessary for the completion of this Work.
3. If two or more bids are tied, the bid will be awarded to the respondent earning the most points from the following, each being assigned one point for a total of up to three points:
  - a) One point to a respondent that certifies compliance with s. 288.703(1), F.S., as a certified minority business enterprise;
  - b) One point to a respondent that certifies compliance with s. 295.187(3)(a), F.S., as a certified veteran's business enterprise; and
  - c) One point to a respondent that certifies compliance with s. 287.087, F.S., having implemented a Drug-Free Workplace program.
4. If there is still a tie, the tie will be broken by lot (for example, coin toss).

**PART 5. FORMS**

**5.1 BID FORMS**

**DEVIL’S HOLE BOARDWALK REPLACEMENT  
ITB 25B-002  
BID SHEETS**

ITEM	DESCRIPTION	TOTAL LUMP SUM BID
1	<b>Devil’s Hole Boardwalk -</b> Remove and replace approximately 75 linear feet of boardwalk and stairs with ADA grab bars at the Devil’s Hole Recreation Area*	\$ _____

\*The Lump Sum Bid listed above shall include all costs associated with the completion of the Work including materials, labor and equipment, tools, incidentals, transportation, mobilization, demobilization, all costs including safety measures for compliance with the Trench Safety Act (Ch. 553, F.S.), and permits as applicable and to complete all services necessary for the completion of the Work specified in the Scope of Work.

\_\_\_\_\_  
Authorized Signature

\_\_\_\_\_  
Position or Title

\_\_\_\_\_  
Printed Name of Above Signature

\_\_\_\_\_  
Agency or Company

I certify that this bid is made without subsequent understanding, agreement or connection with any corporation, firm, or person submitting a bid for the Devil's Hole Boardwalk Replacement Project ITB and is in all respects fair and without collusion or fraud. I agree to abide by all conditions of this bid and certify that I am authorized to sign this bid for the Bidder and that the Bidder is in compliance with all requirements of the Invitation to Bid.

I, the undersigned, having read Parts I through VI of this Invitation to Bid 25B-002 and the attached draft agreement for the project, as well as the Scope of Work and the referenced construction plans, and having a comprehensive understanding of all provisions, rules, requirements, restrictions, etc. contained herein, agree to same and respectfully submit the bid contained herein.

It is the duty of every state officer, employee, agency, special district, board, commission, contractor, and subcontractor to cooperate with the inspector general in any investigation, audit, inspection, review or hearing pursuant to *Section 1.19* above.

\_\_\_\_\_  
Authorized Bidder Signature

\_\_\_\_\_  
Bidder Title

\_\_\_\_\_  
Bidder Name (Print or Type)

\_\_\_\_\_  
Company Name

\_\_\_\_\_  
Date

\_\_\_\_\_  
Address

\_\_\_\_\_  
Area Code Telephone Number

\_\_\_\_\_  
City State Zip

\_\_\_\_\_  
E-mail Address

\_\_\_\_\_  
Federal Employers Identification (FEID#) (Use  
SS # if no FEID #)

---

*(The area below this line is to be completed by NFWFMD Agency Clerk only.)*

Unsigned bids may be rejected by the Agency Clerk of the Northwest Florida Water Management District.

\_\_\_\_\_  
Agency Clerk  
Northwest Florida Water Management District



**5.2 BIDDER INFORMATION FORM**

Years of experience as a General Contractor working in the commercial construction industry performing public access improvements, and/or direct recreational amenities construction projects similar to those described in the Scope of Work: \_\_\_\_\_

Florida Contractor’s License Number(s): \_\_\_\_\_

List of subcontractors, if any, that may be used to perform services:

<u>Name</u>	<u>Address</u>	<u>Type of Firm</u>
_____	_____	_____
_____	_____	_____
_____	_____	_____

List of similar projects that you completed within the past 3 years:

<u>Date (Month/Year)</u>	<u>Location (County/State)</u>	<u>Project Size</u>	<u>For Whom</u>
_____	_____	_____	_____
_____	_____	_____	_____
_____	_____	_____	_____
_____	_____	_____	_____

List of pertinent references, including names, addresses, telephone numbers and email:

<u>Name</u>	<u>Address</u>	<u>Phone Number/Email</u>
_____	_____	_____
_____	_____	_____
_____	_____	_____
_____	_____	_____

Is this bidder a certified minority business enterprise as defined in s. 288.703(1), F.S.? If yes, please provide documentation.

**Check One:**     Yes     No

Is this bidder a certified veteran’s business enterprise as defined in s. 295.187(3)(a), F.S.? If yes, please provide documentation.

**Check One:**     Yes     No

Has this bidder implemented a Drug-Free Workplace program in compliance with s. 287.087, F.S.? If yes, please provide documentation.

**Check One:**     Yes     No

## **PART 6. DRAFT AGREEMENT FOR PROJECT**

Please see the attached Draft Agreement for the project. This agreement is subject to change subsequent to legal counsel review.

**Agreement for**  
**Devil's Hole Boardwalk Replacement**

---

**Between**  
**Northwest Florida Water Management District**  
**And**

---

**NFWWMD Contract Number 25-xxx**

This agreement (the "Agreement") is by and between the Northwest Florida Water Management District (hereinafter, the District) and \_\_\_\_\_ (hereinafter, the Contractor). The District and the Contractor hereby agree as follows:

**SECTION 1 – SCOPE OF SERVICES**

The Contractor shall perform and render all services and deliverables hereunder (the "Work") as an independent contractor of the District and not as an agent, representative, or employee of the District. Work shall be provided and performed in accordance with the Contractor's bid response (the "Bid Response") under ITB 25B-002 entitled "Devil's Hole Boardwalk Replacement" incorporated herein by reference, and the Scope of Work incorporated herein by reference as Attachment A.

**SECTION 2 – RESPONSIBILITIES OF CONTRACTOR**

- A. The Contractor is responsible for the timely completion, professional quality, and technical accuracy of all Work provided to the District under the terms of this Agreement. The Contractor shall, without additional compensation, correct or revise any errors, omissions or other deficiencies caused by the Contractor and identified by the District in reports, drawings, and in conjunction with all other Work provided for under this Agreement.
- B. The District's approval of field activities, reports, drawings, other services, and incidental Work or materials furnished hereunder shall not in any way relieve the Contractor of responsibility for the technical adequacy of its Work. For the purposes of this Agreement, technical adequacy shall refer to the performance of all Work in accordance with the Quality Assurance requirements set forth in the Contractor's Bid Response and the generally accepted standards and professional practices. The District's review, approval, acceptance, or payment for any of the Work shall not be construed as a waiver of any rights under this Agreement or of any cause of action arising out of the performance of this Agreement.
- C. The Contractor shall be, and shall remain, liable in accordance with applicable law for all damages to the District caused by the Contractor's negligent performance of any of the Work furnished under this Agreement.
- D. As provided under s. 216.347, F.S., expenditure of District funds for purposes of lobbying, including of the Legislature, judicial branch, or any state agency, is prohibited.
- E. The Contractor's obligations under this Section are in addition to the Contractor's other expressed or implied assurances under this Agreement or state law and in no way diminish any other rights that the District may have against the Contractor for deficiencies in Work.

- F. The Contractor shall indemnify and hold harmless the District, and its officers and employees, from liabilities, damages, losses, and costs, including, but not limited to, reasonable attorneys' fees, to the extent caused by the negligence, recklessness, or intentionally wrongful conduct of the Contractor and other persons employed or utilized by the Contractor in the performance of this Agreement.
- G. The Contractor represents that it has not employed or retained any company or person, other than a bona fide employee working solely for the Contractor, to solicit or secure this Agreement and that the Contractor has not paid or agreed to pay any person, company, corporation, individual, or firm, other than a bona fide employee working solely for the Contractor, any fee, commission, percentage, gift, or other consideration contingent upon or resulting from the award or making of this Agreement.
- H. The Contractor certifies that it and any of its affiliates are not on the Scrutinized Companies that Boycott Israel List or engaged in a boycott of Israel. Pursuant to s. 287.135, F.S., the District may immediately terminate this Agreement at its sole option if the Contractor is found to have submitted a false certification; or if the Contractor is placed on the Scrutinized Companies that Boycott Israel List or is engaged in the boycott of Israel during the term of the Agreement. If this Agreement is for one million or more dollars, the Contractor certifies that it is also not on the Scrutinized Companies with Activities in Sudan List, Scrutinized Companies with Activities in the Iran Petroleum Energy Sector List, or engaged with business operations in Cuba or Syria as identified in s. 287.135, F.S. Pursuant to s. 287.135, F.S., the District may immediately terminate this Agreement at its sole option if the Contractor is found to have submitted a false certification or if the Contractor is placed on the Scrutinized Companies with Activities in Sudan List, or Scrutinized Companies with Activities in the Iran Petroleum Energy Sector List, or engaged with business operations in Cuba or Syria during the Term, as defined herein. As provided in s. 287.135(8), F.S., if federal law ceases to authorize these contracting prohibitions, then they shall become inoperative.
- I. The Contractor covenants that it presently has no conflict of interest and shall not acquire any interest which would conflict in any manner or degree with the performance under this Agreement.
- J. Prior to commencing Work, the Contractor shall provide a Performance Bond in an amount of \$XX,XXX.XX, equal to ten percent (10%) of the Contract Price of \$XXX,XXX.XX.
- i. The Performance Bond shall be held by the District to insure contract compliance and to pay any damages sustained by the District due to the Contractor's negligence or breach of contract; provided, however, that such Performance Bond shall not relieve Contractor from its obligation to indemnify as provided in Section 2.F. hereof.
  - ii. A certified Cashier's Check made payable to: "NFWMD" may be provided to the District in lieu of a surety performance bond.
  - iii. Attorneys-in-fact who sign bid bonds and performance bonds must file with each bond a certified and effective dated copy of their power of attorney.
  - iv. The Contractor will be required to execute this Agreement and provide the Performance Bond within ten (10) calendar days of execution.
  - v. The Performance Bond or Cashier's Check amount shall be returned to the Contractor within thirty (30) days of successful completion of all terms and conditions of this Agreement.
- K. Contractor's Warranties.
- i. The Contractor warrants the labor and materials used in performing this Agreement for a period

of one (1) year (the "Warranty Period") from the date of the final payment hereunder. The Contractor warrants that it shall deliver to the District good title to all materials, supplies, and equipment installed or incorporated in the Work and upon completion thereof shall deliver all improvements constructed or placed on District land by the Contractor free and clear from any claims, liens or charges. The Contractor will assign to the District all manufacturers', suppliers' and subcontractors' warranties and guaranties on materials, equipment, fixtures, and labor incorporated into the Work. The Contractors' delivery to the District of all such warranties and guaranties is required as a prerequisite to the final payment. Notwithstanding the Contractor's assignment to the District of such warranties, during the Warranty Period the Contractor shall be responsible for causing the manufacturers, suppliers, and subcontractors to perform their warranty obligations.

- ii. Neither inspection nor payment (including final payment) by the District shall be deemed to be a waiver or release of the Contractor with respect to its obligations to remedy any defect in the Work. No inspection performed or failed to be performed by the District shall be a waiver of any of the Contractor's obligations or be construed as an approval or acceptance of the Work or any part thereof with respect to latent defects or other defects not observed by the District during such inspection.
- iii. The Contractor shall not waive, limit or take any action to prejudice or void any warranties or guaranties as to materials or component parts used in the Work or as to any subcontractor's or sub-subcontractor's work without the District's prior written consent, unless the Contractor's performance of the Work in accordance with the Bid Response results in a waiver of or prejudice to such warranty or guaranty; provided, however, that the Contractor will advise the District in writing prior to performing any such Work which will waive or prejudice any such warranty or guaranty, such notice to be provided as soon as practicable after the Contractor discovers any such issue and, to the extent practicable, the Contractor will not proceed with such portion of the Work until the District provides the Contractor with written notice to proceed.
- iv. The District shall be notified by the Contractor as soon as reasonably practicable if the Contractor discovers that any portion of the Work which has been completed deviates from the requirements of the Contract Documents.
- v. Only materials and equipment which are to be used directly in the Work shall be brought to and stored on District land. After equipment is no longer required for the Work, it shall be promptly removed from District land. Protection of construction materials and equipment stored on District land from weather, theft, damage, and all other adversity is solely the responsibility of the Contractor.
- vi. The Contractor shall instruct the District in the proper use and maintenance of all systems or equipment constituting part of the Work at the time of completion and before final acceptance of the Work.
- vii. The District and the District's inspectors shall at all reasonable times have access to the Work, wherever it is in preparation and progress, provided that such access will not interfere with the Contractor's performance of the Work.
- viii. The District has no responsibility to assist the Contractor in the supervision or performance of the Work. No action, approval or omission to act or failure to advise the Contractor as to any matter by the District shall in any way relieve the Contractor from its responsibility for the performance of the Work in strict accordance with the Contract Documents.

- ix. This Agreement is for the District's benefit, and its successors and assigns, who, as well as the Contractor, may directly enforce all rights and warranties, express or implied herein. To effectuate the District's right to enforce subcontracts, the Contractor hereby assigns to the District the nonexclusive right to bring any actions against subcontractors or sub-subcontractors, in the District's name and at its own cost, without waiver by the District of its right against the Contractor, because of defaults, delays, and defects for which a subcontractor or sub-subcontractor may also be liable. The Contractor shall include in its subcontracts and purchase orders appropriate provisions to assure that subcontractors and sub-subcontractors shall have recourse only against the Contractor and not against the District. Notwithstanding the District's right to enforce subcontracts as specified hereinabove, the District may rely solely upon the Contractor for enforcement of all subcontracts and purchase orders entered into in connection with the performance of the Work.

### SECTION 3 – TRUTH-IN-NEGOTIATIONS

The Contractor certifies that wage rates and other factual unit costs supporting the compensation are accurate, complete, and current at the time of contracting. The original contract price and any additions thereto will be adjusted to exclude any significant sums by which the District determines the contract price was increased due to inaccurate, incomplete, or non-current wage rates and other factual unit costs. All such contract adjustments must be made within one year following the end of this Agreement.

### SECTION 4 – COMPENSATION

- A. Maximum compensation for the Work, as described in Attachment A and the Contract Documents, shall not exceed XXX Dollars and 00/100  
\$XXX,XXX.XX. The District's performance and obligation to pay under this Agreement is contingent upon annual appropriation by the Florida Legislature and/or approval of the District's annual budget.
- B. The Contractor shall submit invoices no more frequently than monthly. Each invoice submitted must be in detail sufficient for pre-audit and post-audit review. A final invoice must be submitted within thirty (30) days after the expiration date of this Agreement to assure the availability of funding for final payment.
- C. Payment of any invoice will be subject to inspection and approval by the District Project Manager or District's designee. The District Project Manager will determine, in his/her sole discretion, whether or not the Contractor has successfully completed the authorized Work as outlined in this Agreement. Payment will not be made until the District receives written authorization to do so by the District Project Manager. Payment will be made upon inspection and approval of the applicable Work within thirty (30) days of receipt of an approved invoice. Invoices shall include the Contractor name and address, invoice number, Contractor taxpayer identification number, date, time period covered by the invoice, the Contract Number of this Agreement, total payment requested, amount previously invoiced, and a signed certification by the Contractor Project Manager that the Work being invoiced has been completed.
- D. Any subcontractor fees and other direct expenses required for completion of the Work will be billed at actual cost without mark-up and must be identified and pre-approved by the District. All travel shall be in accordance with s. 112.061, F.S., and District policy, which requires pre-approval by the District. In such instance, travel expenses must be submitted on District travel forms.
- E. An original invoice, including appropriate backup documentation, shall be submitted to both the

District Project Manager, at the contact information included in Section 6.B., and the District’s Accounting Department at: [AccountsPayable@nfwfwater.com](mailto:AccountsPayable@nfwfwater.com).

**SECTION 5 – TIME OF PERFORMANCE**

- A. This Agreement is effective on the last date of execution by a party (the “Effective Date”) and shall remain in effect \_\_\_\_\_ through March 31, 2025 \_\_\_\_\_, (the “Term”).
- B. The Contractor shall proceed with the Work at such rate of progress to ensure full completion within the Term. It is expressly understood and agreed by and between the Contractor and the District that the Term is a reasonable amount of time in which to complete the Work, taking into consideration the average climatic and economic conditions and other factors prevailing in the locality of the Work.
- C. If the Contractor shall fail to complete Work within the Term, or amendments thereof, then the Contractor shall be in default and shall forfeit the Performance Bond as set forth in Section 18.
- D. By formal amendment in writing and agreed upon by both parties, the District may extend this Agreement for a time period as determined necessary by the District in its sole discretion to complete the Work and subject to availability of appropriated funds in each fiscal year of the District.

**SECTION 6 – APPROVALS AND NOTICES**

- A. All notices and written communication between the parties shall be sent by electronic mail, U.S. Mail, a courier delivery service, or delivered in person addressed to the individuals listed in Section 6.B. If sent by electronic mail, notices shall be considered delivered at 5:00 PM on the day sent, or 9:00 AM the following day if sent after 5:00 PM. If sent via other means authorized by this paragraph, notices shall be considered delivered when reflected by a courier service delivery receipt, other mail service delivery receipt, or when receipt is acknowledged by recipient.
- B. The District Project Manager for this Agreement is identified below:

Benjamin Faure or successor	
Northwest Florida Water Management District	
81 Water Management Drive	
Havana, FL 32333-4712	
Telephone No.:	(850) 539-5999
E-mail Address:	Benjamin.Faure@nfwfwater.com

- C. The Contractor Project Manager for this Agreement is identified below:

Telephone No.:	
E-mail Address:	

- D. No amendment to this Agreement shall be effective unless agreed in writing and executed by the parties hereto.

- E. The District and the Contractor may, by written order designated to be an amendment, agree that additional Work shall be undertaken within the general scope of this Agreement.
- F. The District shall, at its sole discretion, determine whether the Work has been satisfactorily completed.

### **SECTION 7 – INSURANCE**

The Contractor shall maintain adequate insurance coverage at all times as follows: General Liability, with limits no less than \$1,000,000 per occurrence; \$1,000,000 per occurrence for personal injury; and \$1,000,000 for property damage; Automobile Liability, with combined single limit of not less than \$1,000,000; Workers Compensation and Employers Liability, with limits not less than \$1,000,000 for each accident for Bodily Injury by Accident, \$1,000,000 policy limit and \$1,000,000 each employee for Bodily Injury by Disease. Evidence of all such insurance satisfactory to the District shall be furnished prior to beginning operations, and all such insurance policies shall provide for thirty (30) days' notice to the District of cancellation or any material change in the terms of the insurance policies.

### **SECTION 8 – SUBCONTRACTS**

- A. The Contractor shall not subcontract, assign or transfer any Work under this Agreement without the prior written consent of the District. Any subcontractors who may be employed by the Contractor and approved by the District must also adhere to all provisions of this Agreement. Subcontractors included in the Bid Response are pre-approved for use under this Agreement.
- B. The Contractor shall cause the names of subcontractor firms responsible for portions of the Work to appear on such Work.
- C. The Contractor agrees to notify the District of all subcontracts no less than ten (10) days prior to the effective date of the subcontracts for the purpose of approval by the District. The Contractor agrees to provide the District with an executed copy of all subcontracts within ten (10) days after the effective date thereof.
- D. The Contractor agrees to be responsible for the fulfillment of all Work elements or arrangements included in the subcontracts and agrees to be responsible for the payment of all monies due under any subcontract and hold the District harmless from any liability or damages arising under or from any subcontract hereunder.

### **SECTION 9 – LAW COMPLIANCE**

The Contractor will abide by and assist the District in satisfying and complying with all applicable federal, state, and local laws, rules, regulations and guidelines, executive orders and policies related to performance under this Agreement.

### **SECTION 10 – TERMINATION OF AGREEMENT**

- A. The District or its designated representatives will decide all questions, difficulties, and disputes of whatever nature which may arise under or by reason of this Agreement. The District's decision upon all claims, questions and disputes shall be final, conclusive, and binding upon the parties hereto. This Section 10 does not preclude any party from seeking relief by filing a petition for administrative hearing pursuant to Ch. 120, F.S.
- B. If the Contractor fails to fulfill its obligations in a timely and proper manner under this Agreement, or if the Contractor violates any of the covenants, agreements, or stipulations of this Agreement, the



District has the right to terminate this Agreement. This right to terminate will be exercised by giving written notice to the Contractor of such termination and specifying the reason and effective date thereof. Upon such notice of intent to terminate this Agreement by the District, the Contractor will have a contract resolution period not to exceed thirty (30) days to resolve deficiencies, disputes or other contract issues to the District's satisfaction before the termination is final. During this resolution period, the Contractor will not initiate any new Work requiring additional compensation without written approval by the District.

- C. The District may at any time and for any reason give notice of immediate termination of this Agreement at the District's convenience and sole discretion. Upon receipt of such notice, the Contractor shall, unless the notice directs otherwise, immediately discontinue the Work and procurement for all materials and services in connection with the performance of this Agreement.
- D. Upon termination in any event, the Contractor shall not be relieved of liability to the District for damages sustained by the District because of any breach of this Agreement, without prejudice to any other rights the District may have as a result of such breach, including, but not limited to, the right to consequential or incidental damages.
- E. In the event the District terminates this Agreement, other than for breach by the Contractor, the Contractor shall be compensated for Work completed as of the date of termination and for any irrevocable commitments for procurement for materials or services made by the Contractor as of the date of termination. The Contractor agrees that it will make no such commitments prior to receiving written approval from the District. The Contractor also agrees to provide all Work products completed or in progress at the date of termination.

#### **SECTION 11 – OWNERSHIP OF DOCUMENTS AND DELIVERABLES**

- A. The Contractor will provide the District with any and all reports, plans, models, geographic information system data, studies, maps, or other documents resulting from the Work. Unless otherwise specified, all written materials, documents, plans, model results, and maps shall be submitted to the District in editable electronic format by the Contractor, and hard copies shall be provided as requested by the District. All digital photos, graphics, and maps shall be of sufficient quality to be reproducible.
- B. The Contractor shall be responsible for the validation of all field and analytical data collected by the Contractor and shall be responsible for the accuracy of all reports submitted to the District.
- C. All reports produced and other data gathered by the Contractor for the purpose of this Agreement shall become the property of the District without restriction or limitation upon their use and shall be made available by the Contractor at any time upon request of the District.
- D. All deliverables, including Work not accepted by the District, are District property when Contractor has received compensation therefor, in whole or in part. For any Work subject to patent or copyright, such Work is a "work made for hire" as defined by the patent and copyright laws of the United States. Contractor shall not make any representation otherwise and, upon request, shall sign any documents so affirming. Any District source documents or other District or non-District documents, specifications, materials, reports, or accompanying data developed, secured, or used in the performance of the Work, excluding proprietary materials, as outlined in the Contract Documents, are District property and shall be safeguarded and provided to the District upon request. This obligation shall survive termination or expiration of this Agreement.
- E. The District shall have the unrestricted right to use and disseminate all of the above-referenced documents without payment of further compensation to Contractor, provided that any future use for

other than the purpose intended by this Agreement shall be at the District's sole risk and without liability to Contractor. Contractor shall include language in all subcontracts clearly indicating that ownership and copyright to all materials produced pursuant to this Agreement remains with the District, as provided herein. All original sketches, tracings, drawings, computation details, calculations, field books, and plans that result from the Work shall become the sole property of the District. Contractor shall submit all such work products to the District, if requested. Contractor may retain copies of all work products created pursuant to this Agreement.

## **SECTION 12 – RELEASE OF INFORMATION**

The Contractor agrees not to divulge any information obtained in connection with the performance of services under this Agreement to anyone other than the District unless authorized in writing by the District. All drawings, specifications, diagrams, reports, documents, etc., furnished by the Contractor pursuant to this Agreement shall become the sole property of the District, and may be subject to disclosure by the District under Ch. 119, F.S., Florida Public Records Law, or required by court order. However, the Contractor shall maintain the confidentiality of the project and all related information unless such confidentiality is waived by the District in writing.

## **SECTION 13 – CHOICE OF LAW/FORUM**

The parties hereby agree that any and all actions or disputes arising out of this Agreement shall be governed by the Laws of the State of Florida; and any such actions shall be brought in state court in Leon County, Florida. The parties hereby agree to waive any rights they may have to file or remove an action to any U.S. district court.

## **SECTION 14 – VENDOR LIST (PUBLIC ENTITY CRIME/DISCRIMINATION/ANTITRUST VIOLATOR) AND NON-PROFIT ORGANIZATION**

- A. A person or affiliate who has been placed on the convicted vendor list following a conviction for a public entity crime may not submit a bid on a contract to provide any goods or services to a public entity, may not submit a bid on a contract with a public entity for the construction or repair of a public building or public work, may not submit bids on leases of real property to a public entity, may not be awarded or perform work as a contractor, supplier, subcontractor, or consultant under a contract with any public entity, and may not transact business with any public entity in excess of the threshold amount provided in s. 287.017, F.S., for CATEGORY TWO for a period of 36 months from the date of being placed on the convicted vendor list pursuant to s. 287.133, F.S. Questions regarding the convicted vendor list may be directed to the Florida Department of Management Services, State Purchasing Division, at (850) 488-8440 or send email to [purchasingcustomerservice@dms.fl.gov](mailto:purchasingcustomerservice@dms.fl.gov).
- B. An entity or affiliate who has been placed on the discriminatory vendor list may not submit a bid, proposal, or reply on a contract to provide any goods or services to a public entity, may not submit a bid, proposal, or reply on a contract with a public entity for the construction or repair of a public building or public work, may not submit bids, proposals, or replies on leases of real property to a public entity, may not be awarded or perform work as a contractor, supplier, subcontractor, or consultant under a contract with any public entity, and may not transact business with any public entity pursuant to s. 287.134, F.S. Questions regarding the discriminatory vendor list may be directed to the Florida Department of Management Services, State Purchasing Division, at (850) 488-8440 or send email to [purchasingcustomerservice@dms.fl.gov](mailto:purchasingcustomerservice@dms.fl.gov).
- C. A person or affiliate who has been placed on the antitrust violator vendor list following a conviction or being held civilly liable for an antitrust violation may not submit a bid, proposal, or reply on any contract to provide any good or services to a public entity, may not submit a bid, proposal, or reply

on any contract with a public entity for the construction or repair of a public building or public work, may not submit a bid, proposal, or reply on leases of real property to a public entity, may not be awarded or perform work as a grantee, supplier, subcontractor, or consultant under a contract with a public entity, and may not transact new business with a public entity pursuant to s. 287.137, F.S. Questions regarding the antitrust violator vendor list may be directed to the Florida Department of Management Services, State Purchasing Division, at (850) 488-8440 or send email to [purchasingcustomerservice@dms.fl.gov](mailto:purchasingcustomerservice@dms.fl.gov).

- D. Pursuant to s. 216.1366, F.S., if Contractor meets the definition of a non-profit organization under s. 215.97(2)(m), F.S., Contractor must provide the District with documentation that indicates the amount of state funds:
- i. Allocated to be used during the full term of the contract or agreement for remuneration to any member of the board of directors or an officer of Contractor.
  - ii. Allocated under each payment by the public agency to be used for remuneration of any member of the board of directors or an officer of the Contractor.

The documentation must indicate the amounts and recipients of the remuneration. Such information must be posted on the state's contract tracking system and maintained pursuant to s. 215.985, F.S., and must be posted on the Contractor's website, if Contractor maintains a website.

#### **SECTION 15 – ACCESS TO RECORDS FOR THE PURPOSE OF AUDITS**

- A. The Contractor shall maintain books, records, and documents directly pertinent to performance under this Agreement in accordance with generally accepted accounting principles consistently applied. The District, the state, inspector general or their authorized representatives shall have access to such records for audit purposes during the Term, or Renewal Term, if applicable, and for five (5) years following the termination or expiration of this Agreement. In the event any Work is subcontracted, the Contractor shall similarly require each subcontractor to maintain and allow access to such records for audit purposes.
- B. Contractor shall comply with Florida Public Records Law under Ch. 119, F.S. Records made or received in conjunction with this Agreement are public records under Florida law, as defined in s. 119.011(12), F.S. Contractor shall keep and maintain public records required by the District to perform the services under this agreement.
- C. This Agreement may be unilaterally canceled by the District for unlawful refusal by the Contractor to allow public access to all documents, papers, letters, or other material made or received by the Contractor in conjunction with this Agreement and subject to disclosure under Ch. 119, F.S., and Section 24(a), Article I, Florida Constitution.
- D. If the Contractor meets the definition of "Contractor" found in s. 119.0701(1)(a), F.S., then the following requirements apply:
- i. A request to inspect or copy public records relating to this Agreement for services must be made directly to the District. If this District does not possess the requested records, the Contractor must provide the records to the District or allow the records to be inspected or copied within a reasonable time. If the Contractor fails to provide the public records to the District within a reasonable time, the Contractor may be subject to penalties under Ch. 119, F.S., or as otherwise provided by law.

- ii. Upon request from the District's custodian of public records, the Contractor shall provide the District with a copy of the requested records or allow the records to be inspected or copied within a reasonable time at a cost that does not exceed the cost provided in Ch. 119, F.S., or as otherwise provided by law. All records that are stored electronically must be provided to the District in a format that is compatible with current information systems.
- iii. The Contractor shall identify and ensure that all public records that are exempt or confidential and exempt from public records disclosure requirements are not disclosed except as authorized by law during the Term, Renewal Term, if applicable, and following termination or expiration of the Agreement if the Contractor does not transfer the records to the District.
- iv. Upon completion of this Agreement, the Contractor shall transfer, at no cost to the District, all public records in possession of Contractor or keep and maintain public records required by the District to perform the services under this Agreement. If the Contractor transfers all public records to the District, the Contractor shall destroy any duplicate public records that are exempt or confidential and exempt from public records disclosure requirements. If the Contractor keeps and maintains public records upon completion of the Agreement, the Contractor shall meet all applicable requirements for retaining public records.

**E. IF THE CONTRACTOR HAS QUESTIONS REGARDING THE APPLICATION OF CH. 119, F.S., OR TO THE CONTRACTOR'S DUTY TO PROVIDE PUBLIC RECORDS RELATING TO THIS AGREEMENT, CONTACT THE DISTRICT'S CUSTODIAN OF PUBLIC RECORDS by telephone at (850) 539-5999; by email at [ombudsman@nfwwater.com](mailto:ombudsman@nfwwater.com); or by mail at Northwest Florida Water Management District, 81 Water Management Drive, Havana, FL 32333.**

#### **SECTION 16 – AGENCY INSPECTORS GENERAL**

The Contractor understands and shall comply with s. 20.055(5), F.S., which states: It is the duty of every state officer, employee, agency, special district, board, commission, contractor, and subcontractor to cooperate with the inspector general in any investigation, audit, inspection, review, or hearing pursuant to this section.

#### **SECTION 17 – PAYMENTS**

- A. Payment will be made upon inspection and approval of the Work and within thirty (30) days of receipt of an approved invoice, submitted in sufficient detail for a pre-audit and post-audit review.
- B. The Contractor agrees to participate in electronic funds transfer payments from the District.

#### **SECTION 18 – FINANCIAL CONSEQUENCES; REMEDIES**

- A. In accordance with s. 287.058(1)(h), F.S., the District will apply financial consequences for nonperformance. If the Contractor fails to complete the Work within the Term or amendments thereof, but does complete the Work within thirty (30) days after the Term, the compensation therefor shall be reduced by two percent (2%). If the Contractor fails to complete the Work within the Term or amendments thereof, but does complete the Work after thirty (30) days but within sixty (60) days after the Term, the compensation therefor shall be reduced by five percent (5%).

- B. If the Contractor shall fail to complete the Work within sixty (60) days after the Term or amendments thereof, then the Contractor shall be in default and shall forfeit the performance bond required in Section 2.
- C. Cumulative Remedies. The rights and remedies of the District in this section are in addition to any other rights and remedies provided by law or under this Agreement.

### **SECTION 19 – EXECUTION OF COUNTERPARTS**

This Contract may be executed in two or more counterparts, each of which together shall be deemed an original, but all of which together shall constitute one and the same instrument. In the event that any signature is delivered by facsimile transmission or by e-mail delivery of a ".pdf" format data file, such signature shall create a valid and binding obligation of the party executing (or on whose behalf such signature is executed) with the same force and effect as if such facsimile or ".pdf" signature page were an original thereof.

### **SECTION 20 – AGREEMENT AS INCLUDING ENTIRE AGREEMENT; SEVERABILITY**

The contract documents (“Contract Documents”) which make up this Agreement consist of: (i) this Agreement document, (ii) Invitation to Bid 25B-002, (iii) the Bid Response, (iv) technical specifications, (v) all addenda issued prior to the execution of this Agreement, (vi) the proposal submitted by the Contractor, and (vii) all modifications issued subsequent thereto, together with attachments and any exhibits attached hereto. The Contract Documents are part of this Agreement as if attached to this Agreement, whether or not they are actually attached. This Agreement, including the Contract Documents, hereby incorporated by reference, makes up the entire contract of the parties. There are no provisions, terms, conditions, or obligations other than those contained herein; and this Agreement shall supersede all previous communication, representation, or agreements, either verbal or written, between the parties hereto. This Agreement has been delivered in the State of Florida and shall be construed in accordance with the laws of Florida. Wherever possible, each provision of this Agreement shall be interpreted in such manner as to be effective and valid under applicable law, but if any provision of this Agreement shall be prohibited or invalid under applicable law, such provision shall be ineffective to the extent of such prohibition or invalidity, without invalidating the remainder of such provision or the remaining provisions of this Agreement.

### **SECTION 21 – MISCELLANEOUS**

Force Majeure. Neither the Contractor nor the District shall be responsible for a delay in its respective performance under this Agreement if such delay is caused by acts of God, fire, flood, named storms, war, terrorist attacks, strikes, lockouts, acts or intervention of governmental agencies or authorities, court orders, and governmentally declared pandemics, epidemics, health emergencies, plague, quarantine, and travel restrictions.

### **SECTION 22 – OTHER STATUTORY PROVISIONS**

- A. Disclosure of Gifts from Foreign Sources. If the value of the grant or contract under this Agreement is \$100,000 or more, Grantee or Contractor shall disclose to the District any current or prior interest of, any contract with, or any grant or gift received from a foreign country of concern, as defined in section 286.101, F.S., if such interest, contract, or grant or gift has a value of \$50,000 or more and such interest existed at any time or such contract or grant or gift was received or in force at any time during the previous 5 years. Such disclosure shall include the name and mailing address of the disclosing entity, the amount of the contract or grant or gift or the value of the interest disclosed, the applicable foreign country of concern and, if applicable, the date of termination of the contract or interest, the date of

receipt of the grant or gift, and the name of the agent or controlled entity that is the source or interest holder. If the disclosure requirement is applicable as described above, then within 1 year before applying for any grant or contracting with the District, Grantee or Contractor must also provide a copy of such disclosure to the Department of Financial Services.

- B. Food Commodities. To the extent authorized by federal law, the District, its grantees, contractors, and subcontractors shall give preference to food commodities grown or produced in this state when purchasing food commodities, including farm products as defined in section 823.14, F.S., of any class, variety, or use thereof in their natural state or as processed by a farm operation or processor for the purpose of marketing such product.
- C. Anti-human Trafficking. If the Grantee or Contractor is a nongovernmental entity, the Grantee or Contractor must provide the District with an affidavit signed by an officer or a representative of the Grantee or Contractor under penalty of perjury attesting that the Grantee or Contractor does not use coercion for labor or services as defined in section 787.06, F.S.
- D. Iron and Steel for Public Works Projects. If this Agreement funds a “public works project” as defined in section 255.0993, F.S., or the purchase of materials to be used in a public works project, any iron or steel permanently incorporated in the Project must be “produced in the United States,” as defined in section 255.0993, F.S. This requirement does not apply if the District determines that any of the following circumstances apply to the Project:
  - i. iron or steel products produced in the United States are not produced in sufficient quantities, reasonably available, or of satisfactory quality;
  - ii. the use of iron or steel products produced in the United States will increase the total cost of the project by more than twenty percent (20%); or
  - iii. complying with this requirement is inconsistent with the public interest.

Further, this requirement does not prevent the Grantee’s or Contractor’s minimal use of foreign steel and iron materials if:

- iv. such materials are incidental or ancillary to the primary product and are not separately identified in the project specifications; and
- v. the “cost” of such materials, as defined in section 255.0993, F.S., does not exceed one-tenth of one percent (1%) of the total Project Cost under this Agreement or \$2,500, whichever is greater.

Electrical components, equipment, systems, and appurtenances, including supports, covers, shielding, and other appurtenances related to an electrical system that are necessary for operation or concealment (excepting transmission and distribution poles) are not considered to be iron or steel products and are, therefore, exempt from the requirements of this paragraph.

This provision shall be applied in a manner consistent with and may not be construed to impair the state’s obligations under any international agreement.

IN WITNESS THEREOF, the District and the Contractor have executed this Agreement as of the date below written.

Northwest Florida Water Management District  
Havana, Florida

\_\_\_\_\_  
\_\_\_\_\_

By: \_\_\_\_\_  
Lyle Seigler  
Executive Director

By: \_\_\_\_\_  
\_\_\_\_\_  
\_\_\_\_\_

Date: \_\_\_\_\_

Date: \_\_\_\_\_

List of attachment(s)/exhibit(s) included as part of this Agreement:

Specify Type	Letter/ Number	Description (include number of pages)
<u>Attachment A</u>		<u>Scope of Work</u>
<u>Exhibit 1</u>		<u>Contractor's Bid</u>
<u>Exhibit 2</u>		<u>Construction Documents</u>
_____		_____
_____		_____

**Attachment A**  
**Scope of Work**  
**Devil's Hole Boardwalk Replacement Project**

The Work entails the removal and disposal of approximately 75 linear feet of existing damaged boardwalk and stair segments and the replacement of these segments at the Devil's Hole Recreation Area located at 1032 Walsingham Bridge Road, Chipley Florida 32425, (Lat 30.493209, Long -85.518793), Washington County, Florida, according to the attached Devil's Hole Swallet Construction Plans. The contractor shall furnish all materials, labor, equipment, tools, incidentals, transportation, acquire permits as applicable and complete all services necessary for the completion of this Work.

**PROJECT SCHEDULE AND PHASING OF WORK**

The Work will begin upon the successful execution of an Agreement between the Northwest Florida Water Management District and the Contractor. All Work must be completed by March 31, 2025.

**WORK SITE & DISPOSAL OF MATERIALS**

The Contractor will be required to keep the work site clean and free of construction debris and all work materials shall be secured and stored in a neat and organized manner. All construction debris shall be disposed of at an appropriate landfill. The Contractor shall provide scale tickets of disposed debris upon request.

**INVOICING**

The Contractor may submit invoices for **completed Work** no more frequently than monthly. The District will not pay for stored materials and will only pay for work that has been completed according to the plans and specifications provided. If submitting an invoice for a portion of an individual boardwalk Project, the District will measure the total length of boardwalk section that has been completed and is being invoiced for and divide this by the total project distance and then multiply this by the Lump Sum Bid amount for the specific project to determine the invoice total.



**EXHIBIT 1**

**CONTRACTOR'S BID RESPONSE**

(Contractor's Bid response to be inserted following bid)

DRAFT

**EXHIBIT 2**

**DEVIL'S HOLE CONSTRUCTION DOCUMENTS**

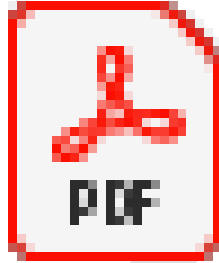

# Devil's Hole Swallet Construction Plans.

DRAFT

APPROXIMATE EXISTING PROFILE OF UNERODED SWALLET BANK. STAIRS TO BE CONSTRUCTED WITHIN THE LIMITS OF THE EROSION GULLY INCLUDING LANDINGS TO CREATE A GRADUAL DESCENT TO THE WATER. CONTRACTOR SHALL NOT IMPACT EXISTING EROSION CONTROL FEATURES FROM PREVIOUS STABILIZATION.

NOTE: MINOR MODIFICATIONS MAY BE NEEDED DURING CONSTRUCTION TO ADJUST LANDINGS AND STAIR TREADS TO FIT WITHIN THE EXISTING PROFILE.

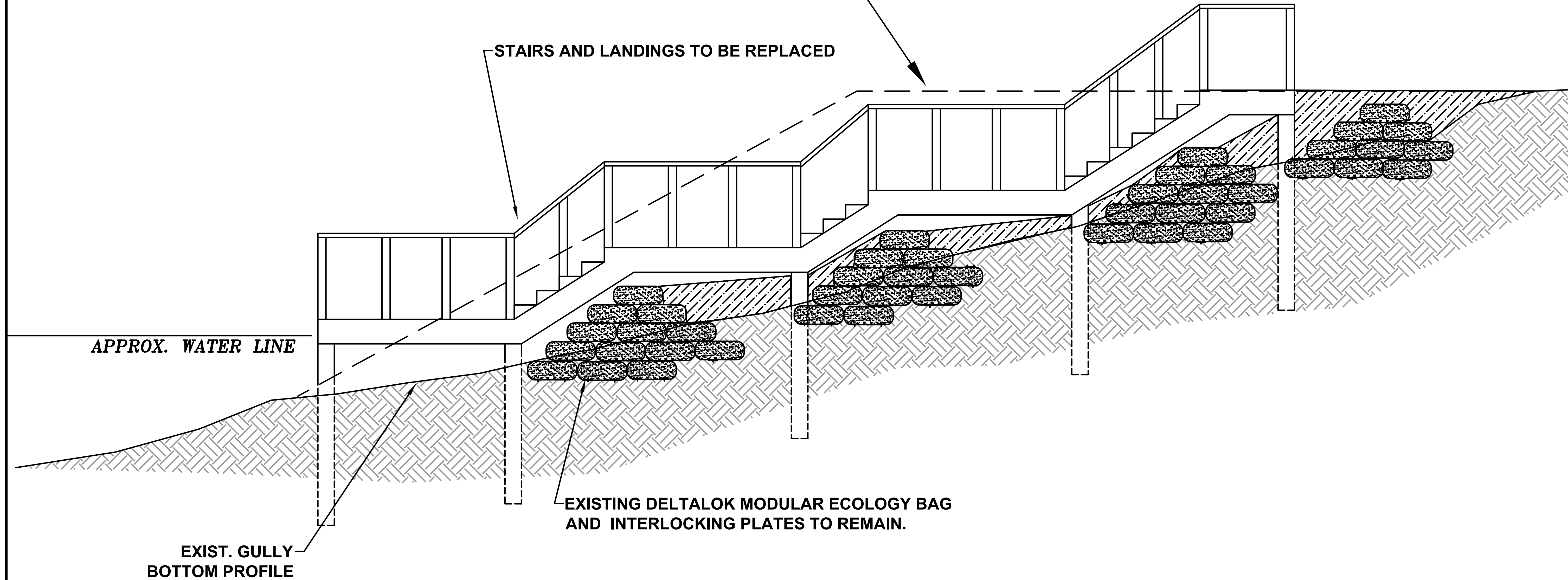

# STABILIZATION PROFILE

NTS

REVISIONS		
DATE	BY	DESCRIPTION

Signed : Linda D. Chaisson, P.E. FL Reg. #51357 SEAL  
 Date : \_\_\_\_\_

PROJECT NAME  
 SHORELINE RESTORATION,  
 PROTECTION AND STABILIZATION  
 DEVIL'S HOLE SWALLET

NORTHWEST FLORIDA WATER MANAGEMENT DISTRICT RESOURCE MANAGEMENT DIVISION				
DATE	COUNTY	DESIGNED BY :	PROJECT #	
SEPT. 2024	WASHINGTON	DRAWN BY :		
		CHECKED BY :		
		APPROVED BY :		

SHEET TITLE  
 STABILIZATION PROFILE

SHEET #  
**1**

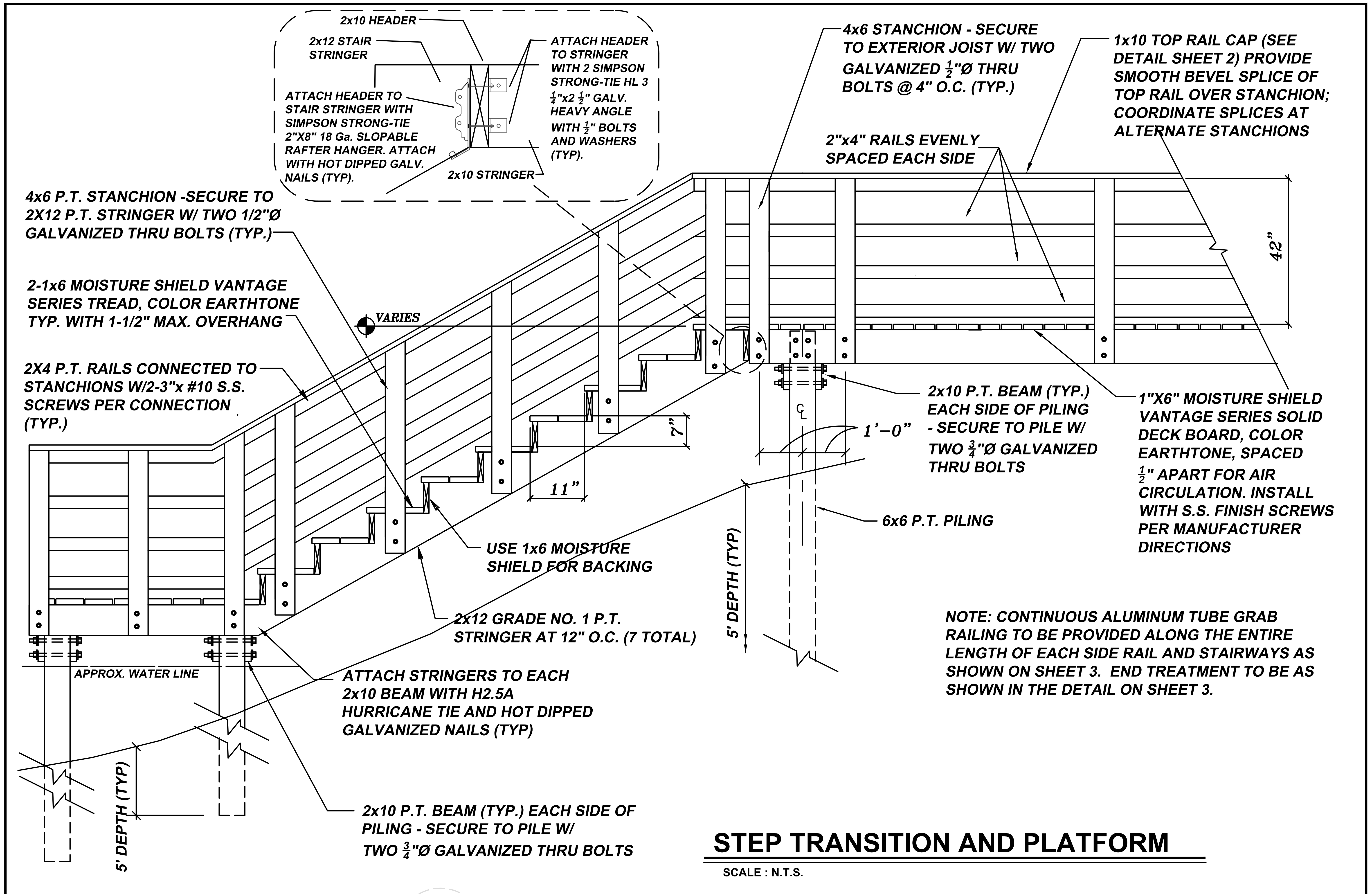

## STEP TRANSITION AND PLATFORM

SCALE : N.T.S.

REVISIONS	
DATE	DESCRIPTION
REV. 1:	
REV. 2:	
REV. 3:	

Signed : Linda D. Chaisson, P.E. FL Reg. #51357 SEAL

Date : \_\_\_\_\_

PROJECT NAME  
 SHORELINE RESTORATION,  
 PROTECTION AND STABILIZATION  
 DEVIL'S HOLE SWALLET

NORTHWEST FLORIDA WATER MANAGEMENT DISTRICT RESOURCE MANAGEMENT DIVISION			
DATE	COUNTY	DESIGNED BY :	PROJECT #
SEPT. 2024	WASHINGTON	DRAWN BY :	
		CHECKED BY :	
		APPROVED BY :	

SHEET TITLE  
 STAIR / BOARDWALK  
 DETAILS

SHEET #  
**2**

**NOTE:**  
WOOD SHALL BE  
PRESSURE TREATED NO. 1  
SOUTHERN YELLOW PINE,  
0.80 CCA KD-HT

2"x4" EACH SIDE WITH  
BEVELED EDGES

2"x4" RAILS EVENLY SPACED EACH SIDE.  
CONNECTED TO STANCHION WITH 2-3" #10  
S.S. SCREWS AT EACH CONNECTION (TYP.)

1"x6" MOISTURE SHIELD VANTAGE SERIES SOLID  
DECK BOARD COLOR EARTHSTONE SPACED  
1/2" APART FOR AIR CIRCULATION AND PER  
MANUFACTURER DIRECTIONS

SIX 2"x10" JOIST EQUALLY SPACED  
O.C. WITH SIMPSON S.S. #H2.5 TIE AT  
EVERY JOIST AND HOT DIPPED  
GALVANIZED NAILS.

2"x10" BEAMS ONE EACH SIDE OF 6"x6" PILING AND  
FLUSH WITH THE OUTSIDE EDGE OF THE STANCHION

2"x6" X-BRACING ON END OF PLATFORM; SECURE  
TO PILING W/ 3/4"Ø GALVANIZED THRU BOLTS, TYP.;  
PROVIDE SOLID BLOCKING BETWEEN BRACES

**NOTE:**  
EXISTING ALUMINUM LADDER AT  
END OF DECK TO BE REMOVED BY  
CONTRACTOR AND REINSTALLED IN  
A SIMILAR MANNER WHEN DECK IS  
COMPLETE.

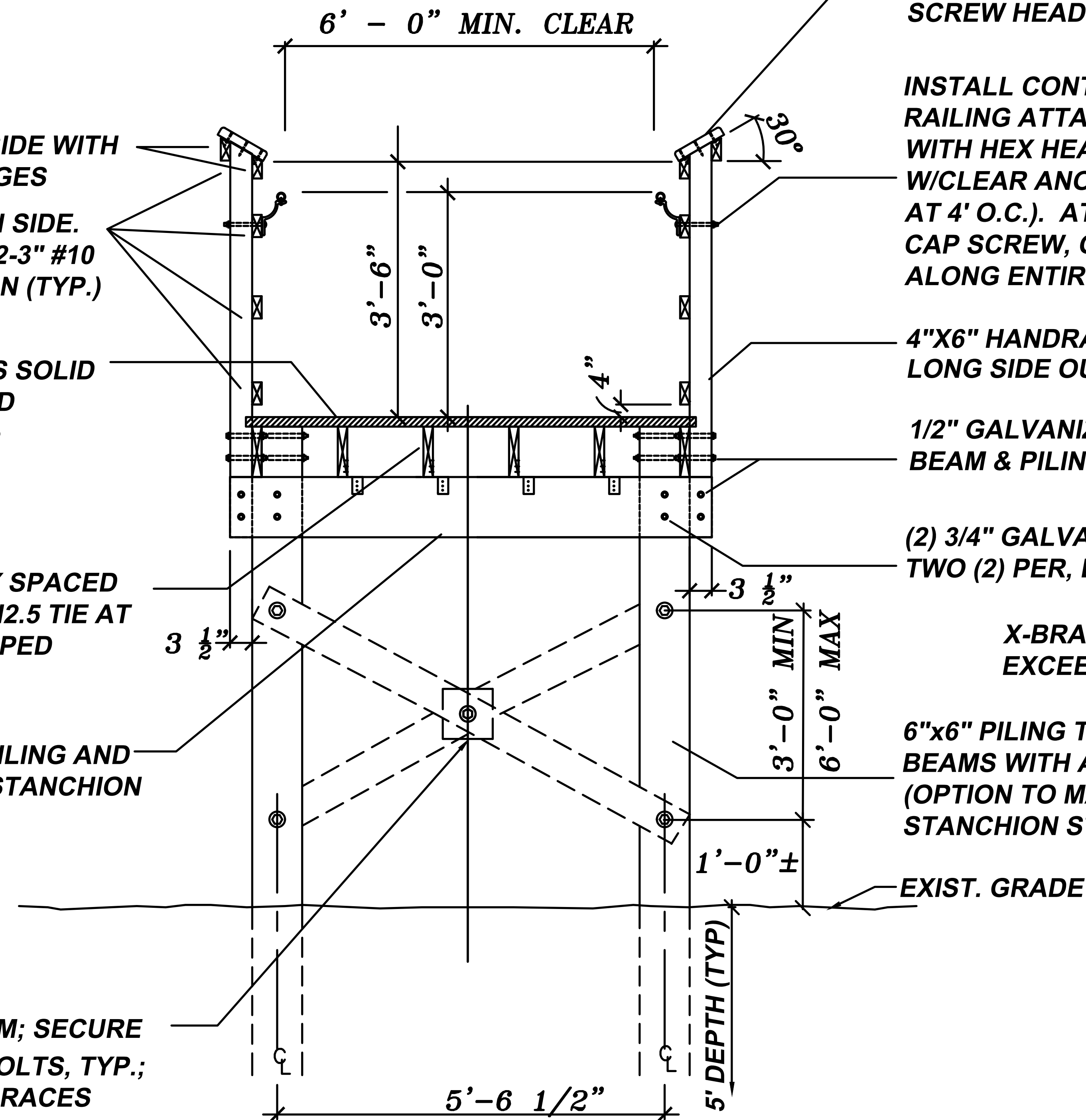

INSTALL 1"x10" MOISTURE SHIELD VANTAGE SERIES FASCIA  
BOARD, COLOR EARTHSTONE. USE MIN (2) FASCIA SCREWS  
COLOR MATCHED EVERY 12 INCHES. USE (3) SCREWS  
AT EACH POST. USE FASCIA TOOL TO COUNTERSINK  
SCREW HEADS.

INSTALL CONTINUOUS 1 3/4"x.125" T-6061 ALUMINUM TUBE  
RAILING ATTACHED WITH 316 S.S. SELF TAPPING FASTENERS  
WITH HEX HEADS TYP., HANDRAIL MOUNTING BRACKET  
W/CLEAR ANODIZED COATING (OR APPROVED EQUAL) (SPACED  
AT 4' O.C.). ATTACH WITH 1/2"Ø x 5" STAINLESS STEEL HEX  
CAP SCREW, ONE (1) PER HANDRAIL STANCHION CONNECTION,  
ALONG ENTIRE BOARDWALK AND STAIRWAYS.

4"x6" HANDRAIL STANCHION TURNED W/ THE  
LONG SIDE OUT WITH A 30° CUT ON THE TOP

1/2" GALVANIZED CARRIAGE BOLT TWO (2) PER JOIST,  
BEAM & PILING CONNECTIONS

(2) 3/4" GALVANIZED CARRIAGE BOLTS  
TWO (2) PER, BEAM & PILING CONNECTION

X-BRACING REQUIRED WHEN DECK ELEVATION  
EXCEEDS 6'-0" ABOVE FINISHED GRADE

6"x6" PILING TO BE NOTCHED FOR BOTH THE JOIST &  
BEAMS WITH A MIN. DEPTH OF 5' BELOW NATURAL GRADES  
(OPTION TO MAKE CONTINUOUS FOR ADDED HANDRAIL  
STANCHION STRENGTH)

EXIST. GRADE

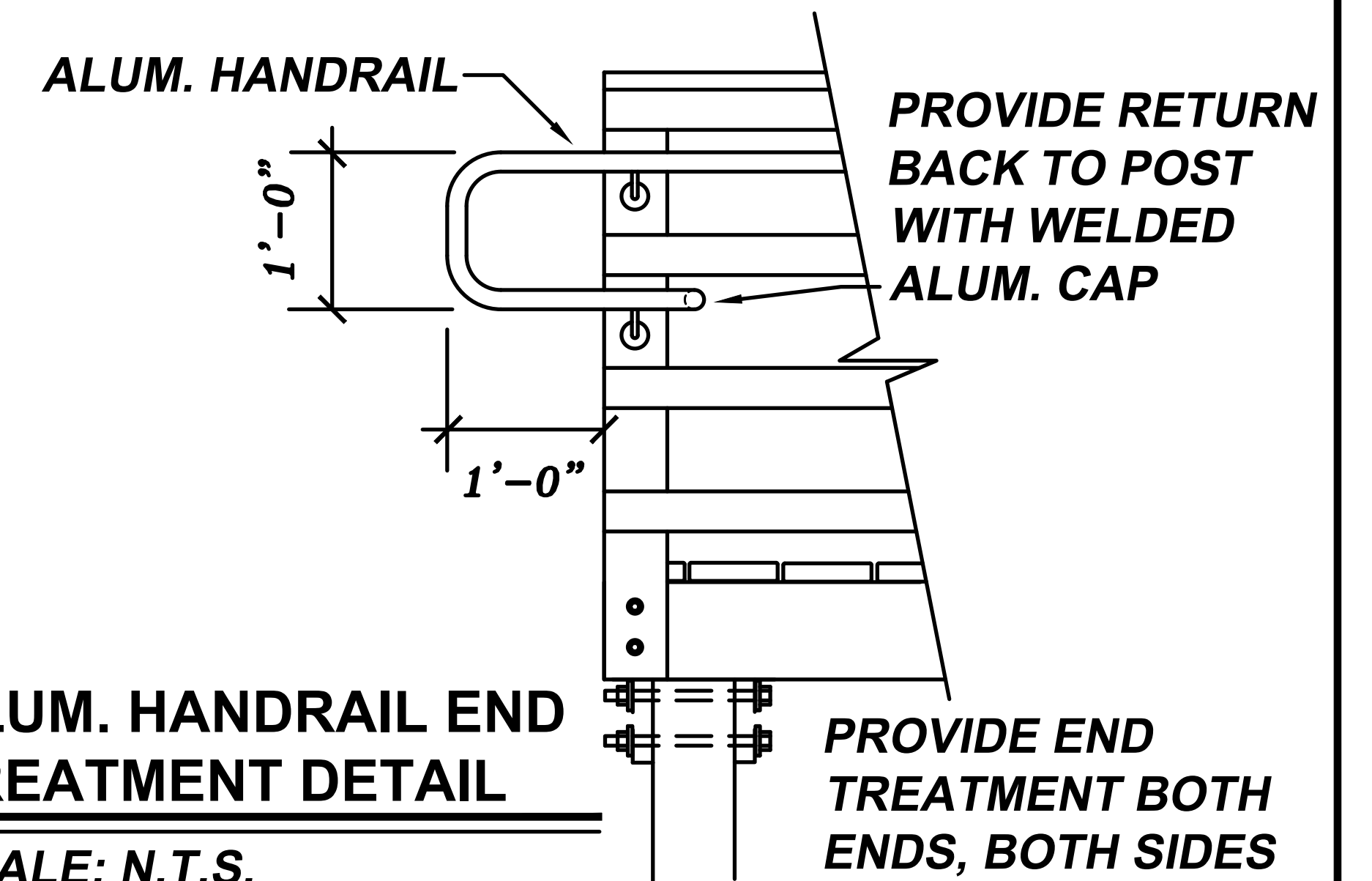

**ALUM. HANDRAIL END  
TREATMENT DETAIL**  
SCALE: N.T.S.

PROVIDE END  
TREATMENT BOTH  
ENDS, BOTH SIDES

## BOARDWALK DETAIL

SCALE: N.T.S.

REVISIONS	
DATE	DESCRIPTION
REV. 1:	
REV. 2:	
REV. 3:	

Signed: \_\_\_\_\_  
Linda D. Chaisson, P.E. FL Reg. #51357-EAL

Date: \_\_\_\_\_

PROJECT NAME  
SHORELINE RESTORATION,  
PROTECTION AND STABILIZATION  
DEVIL'S HOLE SWALLET

NORTHWEST FLORIDA WATER MANAGEMENT DISTRICT RESOURCE MANAGEMENT DIVISION			
DATE	COUNTY	DESIGNED BY:	PROJECT #
SEPT. 2024	WASHINGTON	DRAWN BY:	
		CHECKED BY:	
		APPROVED BY:	

SHEET TITLE  
BOARDWALK  
DETAILS

SHEET #

3